



Unlikely Partners and the Management of Innovation in Communist Europe: A Case Study from the Czechoslovak Textile Machine Industry

Karen J. Freeze

In this paper, I examine the role of management practice and Western partnerships in a revolutionary technology from a Soviet Bloc country: open-end spinning. Debuting in 1967, machines based on this technology tripled productivity in cotton spinning, making life easier for textile workers worldwide. Direct sales or licenses to the West brought Czechoslovakia some 80 percent of its hard currency for over a decade. How could this happen in a Communist country? Exemplary project management: the Czech project leaders understood management practices that became commonplace in the West twenty years later. Equally important were historical infrastructure (Czechoslovakia had been a leading industrial country) and the immediate political and economic context (the reform era that culminated in the Prague Spring of 1968). It benefited from the centrally planned economy: top-down financial support and extreme vertical integration, facilitated close collaboration among researchers, engineers, designers, and machine builders and users. User input from Great Britain and the United States and licensee input from Japan helped turn the machine from a revolutionary innovation into a runaway commercial success.

With shoddy merchandise on half-empty shelves in the stores and legendary shortages of everything from toilet paper to fresh fruits and vegetables, Communist countries throughout the Soviet Bloc appeared to even casual observers to be industrial backwaters, undoubtedly lacking in technological or scientific prowess. Indeed, the command economies were notoriously inflexible and inefficient and usually suppressed any creative management initiatives by local enterprises that might come to the attention of the central administrative organs. Only in 1957, when Sputnik revealed another side of the Soviet economy, did Westerners sit up and take notice. However, that was the space program, part of the military. Surely, economies that could not

Karen J. Freeze <freezek@u.washington.edu> is an affiliate lecturer in the Ellison Center for Russian, East European, and Central Asian Studies at the University of Washington.

supply sufficient or reasonable quality consumer goods were incapable of world-class innovation in other sectors.

Yet, here and there, researchers have found extraordinary exceptions to this general conception of Communist economies, especially after the fall of Communism, when they have enjoyed archival access and engineers, scientists, and managers have felt free to speak. Those of us who began to engage in this kind of detective work in the early 1980s have been pleased to find our hunches vindicated. Most of these countries developed at least one, if not several, breakthrough technologies in various sectors. What is unusual, however, is to be able to track the role of management practices and international partnerships in the success of a specific technology from these countries.¹

Market Forces Push Innovation

After the devastation of World War II, the world was in dire need of textiles for clothing, household goods, and industrial uses. Before the war, the Swiss company Sultzer had developed faster weaving machines, but the so-called classic ring spinning machine, which had emerged around 1830, could not supply the new looms with sufficient yarn.² (See Figure 1 for illustration of the cotton spinning process.) It was clear that faster spinning machines were essential to the future of the industry, so Swiss, German, Japanese, and Czechoslovak companies embarked on R&D (research and development) aimed at innovation in spinning. Rumors about Czech progress filtered to the West, and in 1965 in Brno, Czechoslovakia, foreign textile people got their first glimpse of the Czech machine.³ Skepticism reigned, yet in 1967, the

¹ For a detailed account of the technical side of the story, see Karen Johnson Freeze, “Innovation and Technology Transfer during the Cold War: The Case of the Open-End Spinning Machine from Communist Czechoslovakia,” *Technology & Culture* 48 (April 2007): 249-85. This paper draws heavily on that article for parts of the story.

² Patented in the United States in 1828, the ring spinner became economical in the 1870s. Its predecessor, the slow and labor-intensive spinning mule (1779), persisted alongside the ring spinning machine until the mid-twentieth century because it produced superior fine-cotton and worsted yarns. Ring spinning machines still exist alongside OE (open-end) machines for similar reasons. The most important innovation in weaving before 1950 was the “gripper” (or “missile” or “projectile”) machine built by the Swiss company Sultzer. Simply replacing the large, heavy shuttle with a small yarn-carrying device permitted much higher weaving speeds, which the ring spinners could not match. This resulted in a “reverse salient”; see Thomas P. Hughes’s use of the military image in *American Genesis: A Century of Invention and Technological Enthusiasm* (New York, 1989), 71–73.

³ Nomenclature in Central and Eastern Europe is a sensitive issue. Czechoslovakia came into existence in 1918 as a union of the Czech lands (Bohemia and Moravia, part of the Austrian half of the Austro-Hungarian [Habsburg] empire) and Slovakia (part of Hungary). After World War II, it enjoyed free elections through 1946, when its people gave the Communist Party a 38% plurality that prepared the way for the Communist takeover in February 1948. Stalin died in 1953; we usually date post-

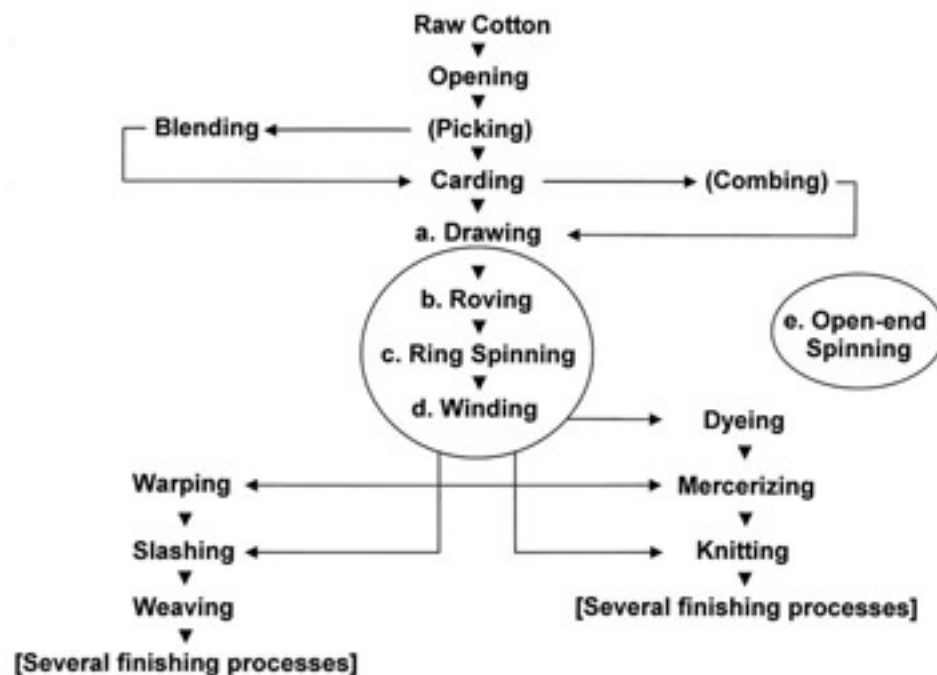

Figure 1. The Cotton Textile Process

Each process in the circles represents a large room full of distinct machines: (a) drawing pulls the carded fibers into thick, untwisted strands called sliver; (b) roving, similar to ring spinning, elongates and twists the sliver slightly into a coarse, weak, heavy yarn; (c) ring spinning further extends and twists the roving into strong, fine yarn, which is wound onto a bobbin held by a spindle; (d) winding takes the thread from the small bobbin and winds it onto a large, cylindrical or cone-shaped package ready for the fabric producer; (e) open-end spinning combines three operations, b–d, producing yarn directly from sliver and winding it directly onto large packages.

BD 200 (from *bezvřetenové dopřádání* [spindleless spinning] and the machine's 200 "heads" or rotor spinning units) made its world debut near Basel, Switzerland. Its technology, called "open-end" (OE) spinning in English, already boasted three times the productivity of the ring spinners.⁴ It

Stalinism from 1956 when Nikita Khrushchev condemned his predecessor's actions and launched reforms. In 1960, Czechoslovakia became the Czechoslovak Socialist Republic (ČSSR); and on January 1, 1993, it split into two countries, the Czech Republic and Slovakia. Because the technology discussed here was developed in the Czech part of the ČSSR, primarily by Czechs, I often use "Czech" as an adjective and ethnic designator; whenever the subject has more to do with the state (for example, the economy, politics, trade, nationality) I use "Czechoslovak." Because the region (Central Europe) was commonly called "Eastern Europe" during the Cold War, I also use that term.

⁴ We call such equipment both "open-end" spinning (because the fibers are separated completely from each other, end-to-end, inside the rotor, before emerging twisted

was also more worker-friendly, with less noise, dust, and, most importantly, fewer backaches: spinners could stand to service it, rather than bending over in non-ergonomic positions. (Figure 2 shows a mid-twentieth-century ring spinning machine; Figure 3 shows the first BD 200.)

Having taken the textile world by surprise, the BC 200, with the vast Soviet market guaranteed, had the West European market to itself for nearly four years. It brought not only recognition to the Czechoslovak state, but also hundreds of millions of dollars in hard currency through sales of machines and licenses. Even after 1976, when it lost its leading position in the West, the BD 200 continued to dominate the industry, either directly or through licensees. A decade later, the Czech BD machines constituted over three-quarters of all OE installations worldwide. By 1987, they were represented in fifty-five countries, and have continued to be sold and resold throughout the developing world.⁵

The fundamental question with which I began my research back in 1982 was, “How could this machine emerge from a Communist system, generally so inimical to innovation and incapable of commercial success?” Based at the time at the Harvard Business School, in a group focusing on the management of technological innovation, I approached the question with the tools I was acquiring through my colleagues’ breakthrough research on new product development and my own, still green, case-study research. As a historian of what we then called Eastern Europe, I was well aware of the historical context of the postwar period, but had no idea what to expect in 1983 as I began interviewing everyone in the Czechoslovak textile machine industry who had been working on any project during these years. I focused, of course, on the BD 200.⁶ After dozens of interviews, supplemented with myriad printed

together into yarn) and “rotor” spinning (because the core of the spinning unit is a rotor). It took some years for “open-end spinning” to become an official patent and industry category. Early efforts were designated in patent records as “continuous spinning,” because they spun directly from sliver (the delicate, continuous, rope-like strands of parallel fibers, 2 to 3 centimeters thick, produced in the carding and drawing processes), and omitted the entirely separate processes of roving (pre-spinning from sliver) and winding the spun yarn from small bobbins onto large spools, or packages. For a clear technical description of open-end spinning, see W. Klein, *New Spinning Systems, Manual of Textile Technology: Short-Staple Spinning Series*, vol. 5 (Manchester, U.K., 1993).

⁵ Countries with BD 200s, 1974–87, are listed in Vilém Fišer, “Technologický servis [Technical Service],” in *40 let VÚB, Ústí nad Orlicí* [40 years of the VÚB, Ústí nad Orlicí], ed. Jaromír Kašpárek et al. (Ústí nad Orlicí, 1989), 155–58. The quantitative side of this story, complicated by fluid statistical standards, is beyond the scope of this paper. Overall, OE machines of all manufacturers accounted for over half of worldwide spinning capacity by 2002.

⁶ A “minder” accompanied me on most interviews in Czechoslovakia in the early 1980s, but once my hosts determined that I was not an industrial spy, they were generally eager to share their stories about this exciting time in their careers (although saying nothing that would reflect poorly on the Communist Party or the



Figure 2. A Ring-Spinning Frame, c. 1940

Note the roving bobbins above, spindles below. From *The Whitin Review* (April 1940), courtesy of the American Textile History Museum.



Figure 3. The Original BD 200

At the Cotton Research Institute in Ústí nad Orlicí, August 1967. The sliver is fed from spools (later cans) below; finished yarn is wound onto large spools at the top. (Courtesy of Rieter CZ, a.s.)

management of research institutes or plants). Interviewees included the former directors and research staffs of the Cotton Research Institute (in Ústí nad Orlicí); the Institute for Textile Technology of Elitex, Concern for Textile Machinery, the Textile Faculty of the Technical University of Liberec, and the State Textile Research Institute (Liberec); the Wool Research Institute, the Knitting Research Institute, and the Institute for Non-Woven Textiles (Brno). After the Velvet Revolution of 1989, most of these research institutes were closed or privatized, and access to their successor institutions was generally less restricted; interviewees, perhaps biased in a different direction, became more candid; and archives (however fragmented and disorganized) became more accessible.

sources, I was able to piece together the story of this innovation and its path to world market success. Startlingly, I discovered that the Czechs were employing project management techniques researched and discussed in American business schools only after 1980. During this early research, I also learned about the Japanese licensee, Toyoda, and the significance of its contribution to legitimizing the BD 200 in the West. At this time as well, I visited American companies that had been early purchasers of the machine and heard their stories.

Not until after the fall of the Iron Curtain, however, did I gain access to archival records in the Czech Republic; nor did I learn about the critical role of a British company, Courtaulds, as the lead user of the BD 200 in the West. Astute project management in the late 1950s and 1960s was the *sine qua non* to be sure, but without user input and close collaboration between the British and Czechs, the machine might not have achieved its runaway success in the West, where textile factories had considerably different demands than those in the Soviet Union and its satellite countries.

My objective in this paper is to tell the story of the BD 200, as well as to analyze the management practices it illuminates within an environment very different from those usually studied.⁷ None of the managers had attended business school; they gained whatever management experience they had in the market economy of pre-Communist Czechoslovakia. Intuitively they ascertained how to accelerate the project and to gain political allies. They also knew how important Western customers and partners would be to the

⁷ Until very recently, there has been little work on innovation in Soviet Bloc countries, and even less on innovations worthy of transfer to the West. Exceptions include works on the former German Democratic Republic; see Johannes Bähr and Dietmar Petzin, eds., *Innovationsverhalten und Entscheidungsstrukturen. Vergleichende Studien zur wirtschaftlichen Entwicklung im geteilten Deutschland, 1945–1990* (Berlin, 1996). Of particular interest in this book is Susanne Franke and Rainer Klump, “Offsetdruck als Herausforderung für innovatives Handeln: Die Innovationsaktivitäten der Druckmaschinenhersteller Koenig & Bauer AG (Würzburg) und VEB Planeta (Radebeul) in den sechziger Jahren,” 215–49. A pioneering work in English is Raymond G. Stokes, *Constructing Socialism: Technology and Change in East Germany, 1945–1990* (Baltimore, Md., 2000). From Ivan Tchalakov, “Innovating in Bulgaria: Two Cases in the Life of a Laboratory before and after 1989,” *Research Policy* 30 (March 2001): 391–402, and “Technological Innovations and Non-Exchange Economy. The Case of Bulgaria (1947–1997),” report for the European Commission Phare program, 1997. On the Czechoslovak auto industry: Valentina Fava, *Socialismo e Taylorism. Organizzazione del lavoro e della produzione negli impianti della Škoda Auto di Mladá Boleslav (1948–1963)* [Socialism and Taylorism. The organization of work and production in the plants of Skoda Auto of Mlada Boleslav (1948–1963)], Ph.D. diss., Bocconi University, 2004. The technology transfer literature was largely unaware of the transfers from East to West; typical is N. Mohan Reddy and Liming Zhao, “International Technology Transfer: A Review,” *Research Policy* 19 (Aug. 1990): 285–307; of 216 works they cite, none has to do with transfer from the Soviet Bloc to the West.

success of their machine, and succeeded (with some failures, to be sure) in wooing them.⁸

Moreover, as if to demonstrate that good management is largely common sense, they exploited the plus side of the centrally planned, command economy, while organizing the project in ways that mitigated the negative side. Their motivations were the same as those of people in a market economy: pride in achievement and personal ambition. Within Communist Czechoslovakia, financial gain was not so significant an incentive, but

⁸ Very few scholars have attempted to address the story of the BD 200, and apart from scattered Czech secondary sources, few works mention Czech literature of any kind; none draw on Czech archival sources, are based in oral history, or seek to embed the narrative in its social, political, and economic context. Jürgen Ripken, *Innovationsprozesse in der Textilindustrie: Das Offen-End-Spinnverfahren* (Frankfurt am Main, 1981) utilizes an extensive source base in German, with a few English titles; he conducted interviews at the Cotton Research Institute (VÚB) in Czechoslovakia, 11–12 Oct. 1977. An insider from the VÚB, Zdeněk Maršíček, disillusioned with the fate of BD technology in the 1980s, wrote a Ph.D. dissertation on the problem, “Tvorba a realizace inovační strategie (Na příkladu technologie bezvřetenového předení) [Creation and realization of innovation strategy (based on the technology of open-end spinning)]” (Ph.D. diss., University of Economics, Prague, 1988). Critical of BD management in the 1980s, the work was not available to the public until after the fall of Communism. Management writers have not been very successful. For example, Thomas Kosche, “Ring oder Rotor? Die Geschichte des Offen-End-Spinnens und einer gründlichen Fehleinschätzung,” *Technikgeschichte* 58 (1991): 209–35, a well-researched account based on German sources, greatly exaggerates the “misestimate” of the demise of ring spinning; in dozens of articles and interviews. I found no one who questioned the enduring place of ring spinning; see for example George Worrall, “Open-End Spinning: A Fabricator’s Viewpoint,” *Modern Textiles* (June 1974), 26. Cristiano Antonelli, “The Role of Technological Expectations in a Mixed Model of International Diffusion of Process Innovations: The Case of Open-End Spinning Rotors,” *Research Policy* 18 (Oct. 1989): 273–88, exhibits serious weaknesses: a faulty understanding of the spinning process; little knowledge of the history of the OE innovation itself; failure to consider political and socioeconomic circumstances in Communist countries; and sloppy numerical data (for example, “\$200,000 [rather than \$200] per rotor head”; “labor costs to spin 1 kg of 24s cotton fell from \$35 [rather than 35 cents] to 30 cents in real terms”). My earliest contribution, “Tradition and Innovation in Technological Development: The Czechoslovak Textile Machine Industry in the 1960s,” in *Technology and Technical Sciences in History. Proceedings of the ICOHTEC [International Committee for the History of Technology] Symposium. Dresden, 25-29 August 1986* (Berlin, 1987), 65–68, was translated into Czech by J. Smekal as, “Tradice a inovace v technologickém vývoji: Československý průmysl textilních strojů v šedesátých letech [Tradition and innovation in technological development: the Czech textile machine industry in the sixties],” *Symposium v Draždanech, srpen [Symposium in Dresden, August] 1986* (n.d.), and is quoted, with the Prague paper, in Josef Ripka, “Historie vývoje rotorového předení [A history of rotor spinning],” in *Vývoj textilního strojírenství v regionu Orlicka* [The development of the textile machine industry in the Orlice region], ed. Václav Klička et al. (Ústí nad Orlicí, 2003), 54–55, 77.

managers coveted the chance to travel to the West as part of the technical teams of installers and maintenance personnel.

The Cotton Research Institute and the Open-end Spinning Project

The Research Institute for Cotton and Silk (Výzkumný ústav bavlnářský a hedvábnický, VÚBH) was established in 1949 in Ústí nad Orlicí, a town of 15,000 located some 150 kilometers east of Prague, in a region with a 500-year tradition of textile production. It offered an industry-specific secondary school, and city administrators and industry representatives eager to welcome such an institute.⁹ In 1951, Václav Rohlena (1913–1986), a rising manager in the textile sector, was appointed the Institute's director. Born to a working-class family, at age 15 he went to work in a spinning plant. Unemployment during the Great Depression radicalized him; soon after the German occupation in 1938, he joined the Czechoslovak Communist Party (KSC). Arrested in 1941, he spent the rest of the war in Nazi prisons. After the war, Rohlena rose quickly within the KSC, ascending to its Central Committee in 1971. His political credentials, enhanced by no small ambition, would prove critical to the BD story.¹⁰

In February 1952, the Ministry of Light Industry directed the VÚBH to address critical issues that beset the struggling textile mills by exploring technology that would:

- a) use new raw materials of local origin with optimal consideration of their specific characteristics;

⁹ For histories of the VÚBH (later VÚB), see Jaromír Kašpárek, "Historie a současný profil ústavu [The history and present profile of the Institute]," in *40 let VÚB, Ústí nad Orlicí*, ed. Jaromír Kašpárek et al., and N. Dostál and Jaromír Kašpárek, "Čtvrtstoletí činnosti Výzkumného ústavu bavlnářského (1949–1974)," [A quarter century of activity in the Cotton Research Institute (1949–1974)], in *Z dějin textilu: studie a materiály. Sborník příspěvků k dějinám textilní a oděvní výroby v ČSSR* [From the History of Textiles. Contributions to the history of textile and clothing manufacture in the ČSSR], vol. 6 (hereafter, *Z dějin textilu 6*), ed. Jaromír Kašpárek and Jaroslav Šůla (Ústí nad Orlicí, 1984), 19–40. For an English-language chronology (1512–2004), see "History"; viewed October 9, 2007. URL: <http://www.rieter.cz/www/rieteren.nsf>. Its introduction to "Czech rotor spinning" quotes almost verbatim my later paper, "An Unlikely Legacy in Technology and Management: The Czech Textile Machine Industry after World War II," paper presented to the 32nd National Convention of the American Association for the Advancement of Slavic Studies (AAASS), Denver, Colorado, 9–12 Nov. 2000.

¹⁰ Biographical data are from Kašpárek et al., *40 let VÚB*, 100–101; and J. Falta, "Dr.-ing. h.c. Václav Rohlena, hrdina socialistické práce, sedmdesátníkem [Dr. Václav Rohlena, hero of socialist labor, on his seventieth birthday]," in *Z dějin textilu 6*: 9–18. Rohlena remains a controversial figure; hated by some for his virtually unlimited power over VÚB workers, he was beloved by Ústí's children as a puppeteer and Father Frost, and universally respected for his role as "the right person at the right time" for the BD project.

- b) utilize lower-quality local materials economically and reduce waste to the minimum;
- c) improve the technology of current manufacturing approaches, both chemical and mechanical;
- d) develop manufacturing methods that would result in higher labor productivity and increased product quality;
- e) improve manufacturing equipment through mechanization, semi-automation, automation, and the design of new machinery; and
- f) improve working conditions in cotton spinning mills.

In addition, VÚBH was to seek scientific-technical cooperation with national enterprises in introducing new methods of work and providing technical services to individual plants.¹¹

From this general mandate, VÚBH gradually began to focus on radically new technologies in weaving and spinning. Partly in reaction to the exhibits at the 1955 International Textile Machine Association (ITMA) trade show in Brussels, Rohlena charged his staff with a new, focused goal: to overcome the traditional limits of ring spinning (the spindle, the ring, and “the damned traveler,” as Rohlena later put it) and single-shed weaving (the pick-beat and pick-beat action).¹²

Two years later, in a 1958 measure echoing Soviet premier Nikita Khrushchev’s economic reforms, the Czechoslovak government decentralized the research institutes and subordinated them to the industries they served. “Silk” moved to its own institute, and the newly focused Cotton Research Institute (now the VÚB) began to report to the head office of the Cotton Industry in Hradec Králové.

VÚB employees assigned to the task of “new spinning principles” had already embarked on what for many would become their life’s work and for all an unforgettable experience.¹³ According to Josef Ripka, their youngest

¹¹ Státní oblastní archiv v Zámrsku [State Regional Archive in Zámrsk] (SOAZ), a regional archive in Zámrsk (in eastern Bohemia) holds the VÚB archives; these materials are not catalogued, but grouped under broad headings and dates in numbered boxes (kartony). I cite references to the collection as SOAZ VÚB, k [box number]. See Dostál and Kašpárek, “Čtvrtstoletí cinnosti,” 21, for a reprint of the first page of this short document (SOAZ VÚB, k 774).

¹² Dostál and Kašpárek, “Čtvrtstoletí cinnosti,” 24; Václav Rohlena, interview with author, 27 Oct. 1983, Ústí. The C-shaped metal traveler regulates the twist and guides the yarn; at accelerated speeds, the traveler can overheat and the yarn will break more frequently (see Fig. 4). Successful ring spinning systems in the late 1990s and early 2000s addressed these problems. In weaving, the shuttle (or other transport means) carries a pick (weft thread) across the shed, the space created through the loom as the harnesses raise the odd, then even, warp threads; a reed then beats the pick against the last row formed. Shuttle-less looms speed up this process rather than change it. VÚB also worked on radically innovative looms that did not succeed in the marketplace.

¹³ For a thorough history of OE spinning, especially the BD project, see Ripka, “Historie vývoje,” 27–81; earlier accounts are found in Milos Wilfert, “Rotorové

member, this cross-disciplinary, intergenerational group was “like a family,” sharing work, meals, and games of volleyball. Together, they labored over theoretical principles, examined and tested myriad approaches to “break” spinning, and combed world patent literature for ideas and limits. They followed their first patent in 1957 with dozens more in rapid succession.¹⁴ In 1961, after years of laboratory trials, they settled on the rotor as the most promising core technology for their new approach.

For a working model, VÚB turned to Kovostav, a nearby machine-building shop founded in 1952 to reconstruct old textile machinery and manufacture spare parts.¹⁵ VÚB’s ensuing collaboration with Kovostav’s machinists and engineers facilitated continuous feedback between research and production, a vital link for the project’s success.¹⁶ On October 5, 1962, they demonstrated a twenty-position model, the DT 20, in which the fundamental elements of the future BD 200 were already in place, including the ergonomically momentous overturning of the traditional path of the spinning process from top-to-bottom to bottom-to-top.¹⁷ Compare Figure 4, the ring-spinning system, with Figure 5, the open-end spinning system.

předení: Vybrané aspekty vzniku a vývoje vynálezecké myšlenky” [Rotor spinning: Selected aspects of the origins and development of an inventive idea], *Z dějin textilu* 6 : 41–55; and Leopold Čížek, “Jak se rodilo bezvřetenové předení” [How open-end spinning was born], *Z dějin textilu* 6: 57–78. See also František Pospíšil et al., “Vývoj rotorového předení ve VÚB [The development of rotor spinning at the VÚB],” in Kašpárek et al., *40 let VÚB*, 103–14. Ripken, *Innovations-prozesse*, used the case of open-end spinning to contribute to the literature on innovation. For OE systems and patents, see Milos Wilfert and Vratislav Zlevor, “Systemy bezvřetenového předení [Systems of open-end spinning],” chap. 2 of Václav Rohlena, et al., *Open-End Spinning* (Amsterdam, 1974), 28–84 and 24–72. They cite attendance by eleven other OE manufacturers (including Toyoda) at the 1971 International Textile Machine Association (ITMA) trade show.

¹⁴ Josef Ripka, interview with author, 18 June 1984, Ústí; he held the same opinion 16 years later (30 Aug. 2000, Ústí). This small group included Leopold Čížek, Ripka, and Josef Hybl. Kašpárek arrived in 1963. Ripka and Kašpárek, the first two researchers with university degrees, headed the theoretical work on the creation of yarn and on the characteristics of fibers and yarn, respectively.

¹⁵ Nationalized in 1949, Kovostav’s attachment to Elitex, the newly founded concern for textile engineering based in Liberec, began in 1961. Kovostav became Elitex-Ústí nad Orlicí in 1976, when, in the government’s aggressive recentralizing move, Elitex became the umbrella concern for the entire Czechoslovak textile machine industry.

¹⁶ Vladislav Hýbl was Kovostav’s general manager. Ladislav Bureš, interview with author, 10 March 1988, Ústí, a Kovostav machinist who headed its BD construction team, suggested that the experience with precision manufacturing of measuring machines was their key advantage.

¹⁷ Industrial designer Alois Richtr, who consulted with the team, later said that it was just “common sense” to rethink the spinning machine configuration so that spinners could work in an upright position (Richtr, interview with author, 7 March 1996, Zlín). See Karen J. Freeze, “Machine and Tool Shaping in Czech: Industrial Design

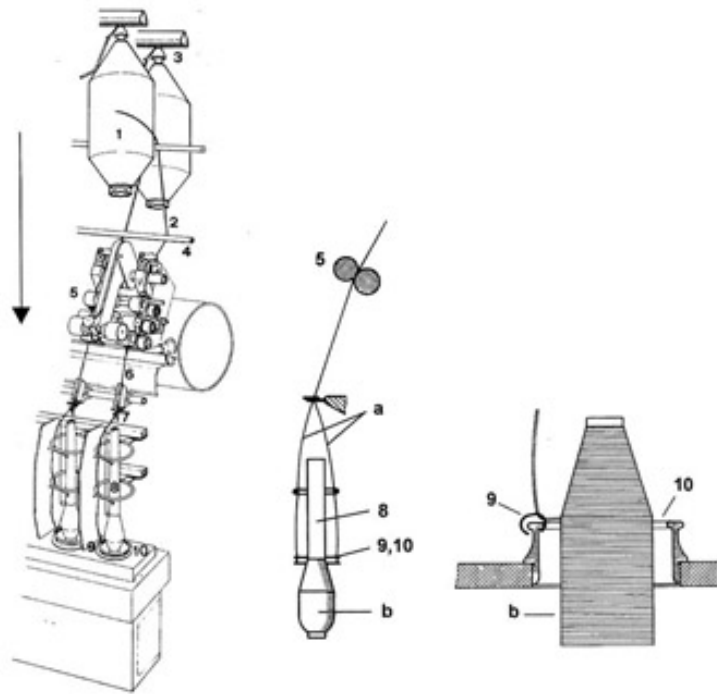

Figure 4. The Ring Spinning System

(1) roving bobbins; (2) roving; (5) drafting arrangement; (7) thread guide; (8) spindle; (9) traveler; (10) ring; (a) "balloon," created as yarn is whipped around the stationary ring, guided by the traveler; (b) partially filled bobbin upon the spindle. The rotating spindle generates twist; its speed is limited by the traveler to approximately 20,000 rpm. The ring, fixed on a rail, moves up slowly and then down quickly until the bobbin is filled. (Adapted from W. Klein, *A Practical Guide to Ring Spinning* [Manchester, U.K., 1987].)

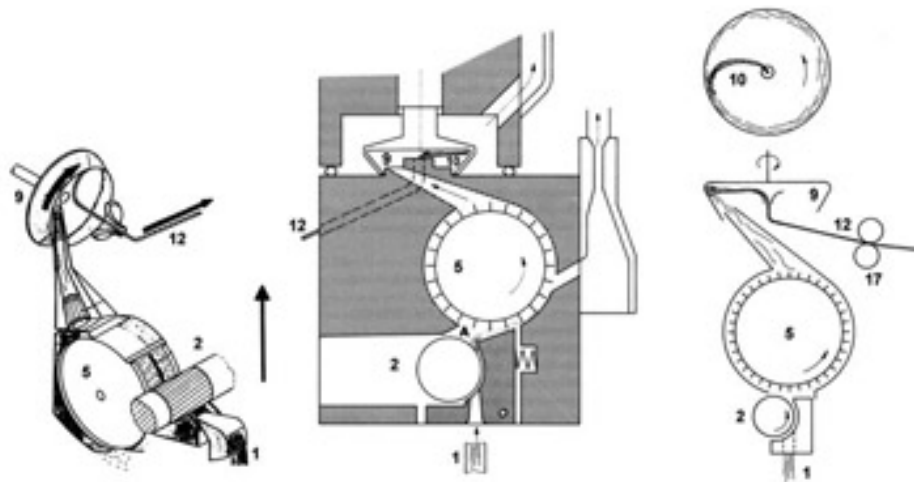

Figure 5. The Open-End (Rotor) Spinning System

(1) sliver, directly from the can; (2) feed roller; (5) opening roller; (9) rotor; (10) free end of the yarn; (12) newly formed yarn; and (17) withdrawal rollers. Today, OE rotors impart twist at over 100,000 rpm; in 1967, the BD 200's rotor speed was 30,000 rpm. (Adapted from W. Klein, *New Spinning Systems* [Manchester, U.K., 1993].)

and Technology in the Czech Republic and its Predecessor States" paper presented to the Society for the History of Technology, annual meeting, Lowell, Mass., 1994.

Shortly afterward they received a Russian visitor, a Mr. Popov, deputy of the chair of the Soviet Union's planning commission. Zdeněk Maršíček, then Director Rohlena's chief assistant, later described the encounter:

Here we were, with only four people working on rotor spinning, and all we had to show was a primitive spinning unit with a combing device and an air jet. We didn't think it was much, but then Popov said, "It's fantastic!! Why do you have only four people working on it? You should have fifty—a hundred—two hundred!" We had never thought of having more than, say, eight people working on any single project, and so [team member] Josef Hýbl asked, "How would that be possible?" Popov replied, "We'll send you fifty Soviet specialists." We thought he was just talking.¹⁸

What was Popov so excited about? As primitive as it was, this machine skipped not one but two steps in traditional spinning, collapsing them into the rotor's mysterious chamber, where uniform yarn was being generated at nearly three times the speed of conventional ring spinning frames (see Figures 1, 4, and 5).

Learning of Popov's reaction to the DT 20, Rohlena consulted with the Minister of Light Industry; together they contacted ČSSR (Czechoslovak Socialist Republic) president and Communist Party chairman Antonín Novotný, urging Soviet-Czechoslovak cooperation in spinning research. Rohlena knew the political implications and practical outcome of such high-level collaboration would be virtually unlimited financial and human resources. He also knew that co-opting the Soviet Union early on would secure its huge market, should VŮB's daring machine reach serial production.¹⁹

Early in 1963, Novotný visited Khrushchev; on April 11, 1963, the Soviet Union and Czechoslovakia signed an agreement to establish what became known in English as the International Center for Open-End Spinning in Ústí nad Orlicí. The goal was to launch the new machine by the fiftieth anniversary of the USSR (Union of Soviet Socialist Republics) in 1967.²⁰

¹⁸ Zdeněk Maršíček, interview with author, 11 March 1988, Ústí. On a visit to a John Deere plant in the United States, Popov had seen research and development teams assigned to explore, in parallel, different solutions to the same problem in order to speed product development. Thus far, I have been unable to track down Mr. Popov in Russian sources, but I have not given up.

¹⁹ Ripka, interview with author, 30 Aug. 2000, Ústí, suggested that Rohlena, who was not present at the meeting, may have stayed away so that Popov would discover the project himself. Čížek ("Jak se rodilo," 66) noted other reasons for wooing the Soviets: to speed up the project and to train them to build and operate the machines in their own country.

²⁰ Participants and observers credited Rohlena with astutely exploiting the ČSSR's relationship to the Soviet Union, agreeing that "without the Soviet Union, this project would have been delayed 10 years." This Center represented the first of several bilateral and multilateral agreements within the countries of the Soviet-sponsored Council for Mutual Economic Assistance (CMEA, also known as Comecon) in textile

Suddenly VÚB's annual budget increased from 500,000 Kčs (Czechoslovak crowns) to 5 million, then to 10 and even 15 million. Dozens of new researchers joined the staff, until nearly two hundred people—over half the VÚB work force—were dedicated to the project.²¹ These included a team from another Czechoslovak textile research center and some eighteen Soviet specialists from research institutes in Moscow and Penza.²²

research; see “Protokol z 11.4.1963 o spolupráci mezi SSSR a ČSSR [Protocol of 11 April 1963 on cooperation between the SSSR and the ČSSR],” SOAZ VÚB, k 627. Each CMEA country specialized in a particular type of machinery; the most sophisticated machines were made in the ČSSR (headquarters of the textile department of the CMEA) and the German Democratic Republic; SOAZ VÚB, k 627 and 683 contain several documents on CMEA cooperation.

²¹ A total investment of 4,895,000 Kčs for 1963 is mentioned in “Řidičí a kontrolní csl.-sovětská komise [The Czechoslovak-Soviet management and control commission],” in “Organizační zajištění československo-sovětského výzkumného a vývojového pracoviště [Organizational securing of the Czechoslovak-Soviet research and development workplace]”; SOAZ VÚB, k 626. Still, it was difficult to recruit qualified people; another 1963 report noted finding only 56 of a targeted 110 new workers, in part because of limited housing; that document concludes with VÚB's plans to build a large apartment complex for employees (“Informace o plnění vládních usnesení číslo 340/63 a 509/63 . . . [Information on the fulfillment of government degree number . . .],” 6 Sept. 1963; SOAZ VÚB, k 47). To ensure further training in the region, VÚB established a four-year, on-site degree program under the Textile Faculty in Liberec. Of 379 VÚB employees in 1966, 38 were university-educated, 262 were technical workers, 30 were administrative staff, and 87 were laborers; Institute staff increased to 509 in 1979, and to 545 in 1982; SOAZ VÚB, k 313. Not everyone worked on the BD project; Ripka noted that during the period from 1963 to 1965, 194 persons were devoted to the New Spinning Principles project, 169 from VÚB, 10 from Kovostav, and 15 from the USSR; see Ripka, “Historie vývoje,” 42.

²² On Soviet-Czech collaboration, see Zdeněk Maršíček, “Vývoj československo-sovětské spolupráce při výzkumu rotorového předení [The development of the Czechoslovak-soviet cooperation in research on rotor spinning],” in Kašpárek et al., *40 let VÚB*, 115–20. Maršíček, interview with author, 11 March 1988, Ústí, recalled that the Soviets represented “Penza, Orla, Moscow, Yerevan, Tashkent; Russians, Jews, Armenians, Uzbeks,” and that they learned Czech quickly. Soviet specialists (10–20 at any one time) and their families stayed in Ústí nearly two years (1963–65), housed in an old castle until a special village was built for them. Čížek (“Jak se rodilo,” 69) wrote that they initially objected to such innovations as a spinning machine “turned upside down”. Still, “Rumor had it,” recalled Inge Dinsdale, formerly a lab technician at VÚB, “that when the machine was unveiled, the Russians wanted to claim that it was *theirs*” (Dinsdale, interview with author, 16 Nov. 2001, Alexandria, Va.). Maršíček (11 March 1988, Ústí) said that Soviet premier Kosygin actually believed the BD 200 was a Soviet invention. Czech technicians also worked with scientists in the Soviet Union and later installed machines there as well. Although some at VÚB considered the Soviet presence nominal, after 2000, more than a decade after Soviet troops left Czech lands, memoirists were more willing to

The researchers at VÚB were divided into several task-specific, interdisciplinary teams, which often pursued parallel paths toward a single objective (such as more uniform yarn) until they determined the best way to meet that objective, a process accompanied by “friendly competition.” People worked day and night, often sleeping in the labs and eating meals provided by management.²³ As team members later testified, the administrators knew that “the best thing [to do] was to leave us alone.” Nonetheless, Ripka recalled, “Rohlena also knew the moment when to take our toys away from us and make us do something with them!” Essential to success was the élan of the group: “We *wanted* to work hard,” was the common refrain, as veterans of the project evoked the spirit of that time. “Our sense of responsibility came from the heart,” said group member Miloslav Pávek.²⁴

The development of open-end spinning in Czechoslovakia over the following three years illustrates the principle of organizing research and development into cross-disciplinary teams working on parallel projects with overlapping problem-solving.²⁵ The first full-size prototype was the KS 200 (for *kontinualní spřádání*, or continuous spinning), completed in mid-1963. While working simultaneously on other solutions to the problem of “getting the fibre in right,” they decided to show a sixty-position version of the KS 200 at the international industrial trade fair in Brno, Czechoslovakia, in September 1965.²⁶ While VÚB was preparing for the exhibition, Kovostav

acknowledge that the Soviets worked competently and diligently. In 1983, Soviet citizen A. A. Barusov received a Czechoslovak state award for his work at VÚB.

²³ For a list of team tasks, see Ripka, “Historie vývoje,” 42. The competitive spirit of the teams was noted by Pávek, interview with author, 21 Nov. 1983, Liberec, among others.

²⁴ Interviews with author: Ripka (30 Aug. 2000, Ústí); Pávek (21 Nov. 1983, Liberec). Rohlena was apparently an excellent delegator who, according to Maršíček (4 July 2001, Ustí) and several others, gave his deputies genuine responsibility rather than trying to micro-manage them. By the early 1980s, “normalization” had largely eradicated the infrastructure for this kind of creativity.

²⁵ In the early 1980s, scholars at the Harvard Business School and other institutions studied this approach to accelerating product development, which they assumed had originated in the Japanese auto industry in the 1970s. It became standard business school teaching by the 1990s. For the germinal work on efficient organization of new product development, see Kim B. Clark and Takahiro Fujimoto, “Overlapping Problem Solving in Product Development,” Harvard Business School Working Paper, 1987. See also Robert H. Hayes, Steven C. Wheelwright, and Kim B. Clark, *Dynamic Manufacturing: Creating the Learning Organization* (New York, 1988), chaps. 10-11.

²⁶ The Brno Fair was second to the Leipzig Fair as a showcase for Socialist and Third World countries; representatives of some Western (especially West German) firms also attended. A document prepared by VÚB for ČSSR president Novotný explained that they wanted to measure the response to the concept of spindleless spinning in a public forum, while keeping the newer model under wraps. “We chose this approach in order to keep our most recent results secret. Even so, the technical level of the original model is so high that it will surely awake extraordinary interest among . . .

constructed a new, full-sized prototype with a different, “combing roller” system. It was soon evident, however, that this machine, the early BD 200, fell far short of expectations. “It was a disaster,” recalled Maršíček. “Three thousand end [yarn] breaks per hour per thousand spinning heads. Our goal was three hundred per thousand!” Although this was just one of several glitches in the program, it barely escaped being the last. According to Maršíček, they actually thought about scrapping the whole project at this point. “After all, it had already cost 40 million Kčs, and we still didn’t have anything that worked.” Help arrived just in time. Josef Houska, director of the department of technical development in the Ministry of Light Industry, urged VÚB to do a new “risk prototype” for another 10 million Kčs. “I’ll take it on my back,” he said. “Forty or fifty million, what’s the difference?”²⁷

Houska’s gamble paid off, for the next prototype scored. By mid-1966, everything fell into place, with only 150 end breaks per hour per thousand spinning units, at this point a remarkable result. It was now time to build a pilot spinning mill adjacent to a plant in Ústí belonging to Perla, one of the largest cotton fabric producers in the country. At the last moment, however, Perla backed out; VÚB’s management took the matter into their own hands and decided to build a spinning mill on VÚB premises that would be just large enough to hold ten full-size machines and preparatory equipment.

In the meantime, the KS 60 represented VÚB’s “new spinning principles” at the Brno fair. People flocked around it, watching how it spun (or appeared to spin) continuously, how the attendant could remove the large spools at the top without stopping the machine, how she could work in a standing position. Rumors about the Czech invention abounded in textile circles after the Brno show. Representatives of the British firms Platt & Co. and Courtaulds Ltd. suspected it did not really spin, that finished yarn was simply being pulled from the “green box” (the color of the sheet metal that covered the KS 60). Nevertheless, textile people hurried to Czechoslovakia to check out the new machine.

A few months after the Brno fair, three West European firms—Platt & Co. (United Kingdom), Ingolstadt (West Germany), and Rieter AG (Switzerland)—expressed interest in licensing the Czech technology on condition of a successful two-week trial in the VÚB lab. Although the results pleased the companies, none took out a license, to VÚB’s disappointment.²⁸

By spring 1967, pilot BD 200 machines were in the works, and a plant to house them was materializing in VÚB’s backyard. Still, only one visitor to VÚB from the West had agreed to any kind of partnership, the British firm

the world press and decision makers who buy textile machines. . . .”; “Informace pro soudruha presidenta Antonína Novotného [Information for Comrade President Antonin Novotný],” 1965 [internal evidence], 5, SOAZ VÚB, k 47.

²⁷ Maršíček, interview with author, 11 May 1988, Ústí, confirmed by Kašpárek (letter to author, 26 Aug. 2004). In the reform climate of 1965, Houska could make such a decision himself.

²⁸ This episode led to some serious patent disputes, all of which VÚB won.

Courtaulds. Because the Japanese had expressed serious interest in a license, Rohlena decided to visit Toyoda Automatic Loom Works and its customer, textile producer Daiwa Spinning Company. It was a delicate situation, Rohlena later recalled: “We didn’t want them to know how much we needed them to legitimize the technology and open up the market.”²⁹

VÚB’s coup was formalized in a licensing agreement signed 11 May 1967 by Toyoda, Daiwa, and Polytechna, the Czechoslovak agency in charge of “non-embodied property.” Daiwa agreed to purchase the first machines Toyoda produced.³⁰ The agreement gave Toyoda exclusive rights to market its BD machines in Asia; the Czechs had a monopoly in Europe. A month later, the Italian company Nuova San Giorgio bought a license to build BD 200 frames, with VÚB to provide spinning units. Textile people had suddenly awakened to the possibilities of this new machine, and VÚB finally had its first Western partners, who would prove essential to the BD 200’s success.

On August 14, 1967, almost three months ahead of schedule, ten BD 200 open-end spinning machines were in place in the “first open-end spinning

²⁹ Interviews with author: Maršíček (10 March 1988, Ústí), and Rohlena (27 Oct. 1983, Ústí). Toyoda was the mother company of automaker, Toyota. Rohlena reported that on an earlier visit to VÚB, the head of Toyoda’s OE project, T. Tooka (subsequently technical director of Toyoda), had recommended that Toyoda scrap its own program and buy a license to manufacture the BD 200. For a report of Rohlena’s trip to Japan made in April 1967 with the ČSSR Minister of Light Industry, see “Cestovní zpráva ze služební cesty do Japonska [Travel report from a business trip to Japan]”; SOAZ VÚB, k 124.

³⁰ In Communist countries, only state agencies had permission to trade intellectual property or goods. In Czechoslovakia, Polytechna handled intellectual property, and Investa (later Strojimport) handled textile machines. The system prevented direct, on-going relationships between producers and customers, and kept producers out of financial negotiations. For license documents, see SOAZ VÚB, k 630; for detailed results, see Zdeněk Maršíček, “Výsledky realizace výkumného úkolu ‘Bezvřetenové předení’ v letech 1967-1982 [The results of the realization of the research task, “Open-end Spinning,” from 1967 to 1982],” in *Z dějin textilu* 6 : 79–104. By the end of 1968, Toyoda had built forty exact copies of the BD 200, to install in the Daiwa’s new OE plant in Fukui; by August 1969, they had manufactured 104. According to Rohlena (interview with author, 27 Oct. 1983, Ústí), when Toyoda discovered that their machines were noisier than the Czech-built BD 200s, they sent part of a machine to Ústí, where the Czechs determined that Japanese machine tooling was insufficiently precise. Toyoda also sent a team to study the organization and flow of the Kovostav plant. Ploc (interview with author, 8 May 2005, Česká Třebová) confirmed that Rohlena loved to tell how the Czechs “taught” the Japanese; in only a few years, the Japanese would be teaching the Czechs. According to a report of 13 May 1970, by J. Kováč and J. Němec; SOAZ, Elitex Ústí nad Orlicí [hereafter EÚO], k 328), Czech engineer Lizec met with W. Powell from Courtaulds, who had discovered in Japan that Toyoda’s BD machines were superior metallurgically and easier to maintain. Because the license agreement forbade Toyoda from exporting to England, Powell reminded Lizec that they could at least ask the Japanese for detailed documentation about changes and improvements.

mill in the world,” on the VÚB campus in Ústí nad Orlicí. What had originally been a disappointment (Perla’s pilot plant would have been five times bigger) turned out to be a blessing.³¹ With the pilot machines located on its premises, VÚB, in collaboration with Kovostav’s engineering designers, could continue to control their development.

In September 1967, a month after the testing mill opened, VÚB introduced the BD 200 in St. Louis, a French border town near the International Textile Machine Association (ITMA) exhibition in Basel, Switzerland.³² Again, the machine drew hundreds of visitors, but elicited more comment than commitment. Neither Toyoda’s license, effective from October 19, nor Courtauld’s purchasing agreement were public knowledge.

Yet textile company representatives continued to visit Ústí, responding not only to the demonstration at ITMA, but also to recent publications about open-end technology. Harold Catling concluded in an article published in Britain in 1968:

Only five years ago, most working spinners saw break-spinning as an esoteric pursuit followed by the lunatic fringe of textile inventors. Since then, a great deal has happened to change this view. Actual machines have been built and openly demonstrated in the United States, Czechoslovakia, France, and Japan, and there is evidence of a great deal of clandestine activity in almost all countries with a textile-machinery industry.³³

A Lead User from the West: Courtaulds

The BD 200 was both a product innovation (for licensees) and a process innovation (for yarn companies). Licensees opened up the market, but only users could ensure sustained sales. Given the key criterion for the machine—

³¹ As Peter Lord later commented, “It is perhaps significant that the Czechs set up their own pilot plant in the early days of the development, rather than relying solely on customer reports. Before this time, it was unusual for Western yarn-machinery makers to concern themselves with more than the machine and its immediate product”; from P.R. Lord, “Commercial Development in Open-end Spinning,” in *The Yarn Revolution: New Developments in the Production of Spun and Textured Yarns and their Exploitation in Fabric Form, Papers of the 60th Annual Conference of the Textile Institute, 1976, Harrogate* (Manchester, U.K., 1976), 12.

³² The ITMA allowed no exhibits from Soviet Bloc countries until 1974. Stokes, *Constructing Socialism*, chap. 3) explores the role of trade fairs in technology transfer and espionage in the two Germanys; certainly for some Czech technicians, ITMA fairs were the only opportunity to evaluate their competitors. In the 1980s, as exhibition design and machine “packaging” became more sophisticated in the West and sometimes overshadowed the machines themselves, the Czechoslovak exhibits at ITMA and ATME (American Textile Machine Exhibition) appeared relatively primitive, such that only people who knew the BD machines from experience or by reputation knew that surface looks did not necessarily matter.

³³ H. Catling, “The Comparative Merits of the Principal Break-Spinning Systems,” in *Studies in Modern Yarn Production* (Manchester, U.K., 1968), 75–95.

production of quality yarn—VÚB needed a volume-based customer willing to provide long-term feedback. Fortunately, Courtaulds Ltd. was seeking the cost-effective quality and productivity promised by the BD 200. As a further benefit, the well-regarded firm was an experienced early-adopter; it did not expect new technology to be free of problems and employed top-level scientists and textile technicians to address the inevitable challenges. In the case of the BD 200, they would perform a service invaluable to everyone concerned on both sides of the Iron Curtain.³⁴

At the Brno trade show in 1965, Dr. Malcolm Jeffrey, manager of the Courtaulds Textile Development Unit, also expressed skepticism about the new Czech machine that claimed to eliminate roving and winding and to spin three times as fast as ring spinners. Because no one had been close to the machine, Jeffrey was inclined to agree with other observers that the yarn might be coming from a hidden spool—that it was, indeed, a Potemkin village, a machine that did not really spin.³⁵ But what if it really did spin? The prospect intrigued Sir Frank Kearton, Courtaulds' ambitious chair. Aiming to thwart competition from the Far East with high volumes, Kearton had already begun to acquire declining textile mills and to seek out new markets. The innovative technology represented by the highly productive, inexpensive Czech invention promised to further his goals.

Kearton was no stranger to the Soviet Bloc or to bold moves. His company, the largest manufacturer of chemical fibers in the world, was already exporting huge amounts of product to the USSR and other East

³⁴ In "How Innovative Are Users? A Critique of Learning-by-Doing and -Using," in *Technology and the Market: Demand, Users, and Innovation*, ed. Rod Coombs et al. (Cheltenham, 2001), 216–33, Remco Hoogma and Johan Schot summarize (and critique) Erik Von Hippel's work, particularly, "The Dominant Role of Users in the Scientific Instrument Innovation Process," *Research Policy* 5 (July 1976): 212–39, which characterizes the best lead users as those who are "competent, resourceful, and have an incentive for innovation." Not until 1999 did I discover the critical role played by Courtaulds Ltd. in the early development of the BD 200; my Czech sources did not talk about it in the 1980s. Ripken, *Innovations-prozesse*, was similarly unaware of the Courtaulds connection. Documents from the "Records of Courtaulds Plc [Ltd. until 1980]" corroborate and elaborate the oral testimony; see Greater Manchester County Record Office Archives, [hereafter GMCA] B/CTLD/1 [box number].

³⁵ Malcolm Jeffrey (letter to author, 26 March 2004) elaborated his role at Courtaulds, later explaining (telephone call to author, 25 April 2004) that his job in the Textile Development Unit was to keep abreast of all new technology that might satisfy customers looking for synthetic fibers. Courtaulds gradually bought most of those customers and operated as a vertically integrated shop, employing new technology of many kinds, including Czech air-jet and water-jet looms. Former Courtaulds scientist Peter Dinsdale, who spent several years working with the Czech technology in the late 1960s and early 1970s, alerted me to Jeffrey's 1965 report (17 March 2001, telephone conversation with author).

European countries.³⁶ In 1965, Courtaulds had begun to test Czech air jet looms and by 1968 was installing several hundred of them in one of its gigantic new mills. On a visit to VÚB in fall 1966, Kearton witnessed the pilot BD 200 in operation and had immediately expressed a desire to buy hundreds of the machines for his growing empire. He and his hosts agreed to exchange visits in January 1967 to discuss cooperative research, licensing, the purchase of Czech machines, and the sale of chemical fibers to the Czechoslovak textile industry.³⁷

Late in 1967, Kovostav packed up BD 200, no. 15, for shipment to Oldham, England, where Czech fitters helped to install it in the Courtaulds Maple Mill. As the first of its kind in a Western country, the “top secret” machine was screened from the view of all but half a dozen technicians. The excellent initial results prompted orders for more; and by mid-1968, forty machines were running in three mills.

Maple Mill faced multiple challenges with the new BD 200. As George Worrall recalled:

Our people really didn't know how the machine worked. They had only very simple brochures which didn't really tell you anything. Other information was available, but you needed a degree in pure mathematics to understand it. People didn't know about maintenance, maintenance schedules, how the parts worked, how soon they would wear out. But, then, of course, neither did the Czechs, since they weren't running their machine non-stop under commercial production conditions.

After a few weeks, the BD 200s began to succumb to abrasiveness—first of American-type cotton, then of synthetic fibers. Having been designed and built around the characteristics of Soviet (Uzbek) cotton, they could not cope

³⁶ See Donald Cuthbert Coleman, *Courtaulds: An Economic and Social History*, vol. 3: *Crisis and Change, 1940-1965* (Oxford, U.K., 1980), for insight into the company's leadership through 1965. The relationship of Courtaulds with the Soviet Union and Poland began as early as the 1950s; Coleman credits Kearton (see chaps. 9 and 12) with the company's success in the Soviet Bloc; his Table 45 (p. 283 in this volume) shows 29, 37, and 25.5 percent of Courtaulds' exports going to the USSR in 1960, 1961, and 1963, respectively. These were often barter deals, made in exchange for machinery.

³⁷ According to George Worrall, then a plant manager and later technical manager in charge of open-end spinning for the company's Northern Spinning Division, Kearton ordered one BD 200 immediately and took out an option on 400 more. Because each promised three times the production of one ring-spinning machine, this was ambitious indeed. Dinsdale and Worrall later confirmed that 400 would be reasonable, given the size of the company. In the end, Courtaulds bought only 150; see Worrall, “Open-End Spinning,” 20–25. The early BD machines purchased by Courtaulds were almost certainly less expensive. On the January meeting, see “Licence na bezvřetenové předení [Licenses for open-end spinning],” 3; SOAZ VÚB, k 286.

with other raw materials, especially viscose. Because the Czechs and the British were equally keen for the BD 200 to spin synthetic fibers and blends, they sought solutions to these problems at both the design and the manufacturing levels. Some simply involved substitute materials, the Czechs finding it difficult to obtain high-quality steel.

Seeking long-term solutions, in August 1968 Courtaulds sent five people to Czechoslovakia: Malcolm Jeffrey, Harold Willets (manager of Maple Mill), Harvey Shaw (manager of the spinning section of the Textile Development Unit), and scientists Martin Wildgust and Peter Dinsdale (recently graduated in physics and mathematics). They immediately set to work, guided by a carefully constructed research protocol that history thwarted: on August 21, which should have been their second full day in Ústí, they awoke to the sight of Soviet tanks. Unaware that the situation was grave, the Englishmen spent the day in the mountains with their hosts; on their return, however, VÚB packed them into a Tatra driven by VÚB's head chauffeur on what became a 3-day expedition to evade Soviet troops and find a border crossing.³⁸

This incident did not deter Kearton, who pursued the technical partnership with VÚB as if the infamous suppression of the Prague Spring had not taken place. Over the next few months, several delegations exchanged visits on both sides of the Iron Curtain. A longer stay in Ústí took place in January 1969, when Peter Dinsdale and George Worrall, then manager of a ring-spinning plant, arrived with ten tons of sliver in Courtaulds blends for the Czechs to experiment with. By the time they left, the two men had most of the information needed to modify and operate their machines back in England.³⁹

In the meantime, since the arrival of the first BD in 1967, a small colony of Czech technicians had been forming around Courtaulds plants in England. George Worrall was in charge of their care:

³⁸ See two questionnaires, one blank and one filled in by hand, as well as an 18-page typed statement in Report No. 36/68, "Break Spinning Visit to Czechoslovakia, 18–23rd August 1968," 29 August 1968 (GMCA B/CTLD/1/12). Peter Dinsdale (interview with author, 16 Nov. 2001, Alexandria, Va.) recounted the adventure: having called the British Embassy in Prague from the VÚB's mountain recreational center in Říčky, he was told, "Stay put. It will blow over. And don't bother us any more—we have a reception tonight." Dinsdale added, "I've never gone to a British Embassy since."

³⁹ The blends were of 100 percent acrylic, viscose, poly-cotton, and poly-viscose. Worrall and Dinsdale prepared a very detailed Visit Report (no. 58/68, 17 Dec. 1968, GMCA B/CTLD/1/13), documenting minute steps in the operation of the VÚB spinning mill. From Worrall's experience in the mill, they concluded that Courtaulds should adopt many of the superior training, maintenance, and operations techniques they had seen at VÚB. Kašpárek confirmed Dinsdale's account from the Czech side in 2004 (letter to author, 26 Aug. 2004). Peter fell in love with Inge, language barriers aside, and married her in Feb. 1970. He stayed involved with his wife's homeland long after leaving Courtaulds, and as a manager in the International Finance Corporation, he was a key player in the privatization negotiations for the Czechoslovak textile machine industry after the Velvet Revolution of 1989.

We had a half dozen [Czechs] at a time, continually working in this country, and they were generally very good, and worked well as a team. Occasionally there were political problems. Then I'd tell them if they didn't shape up, they'd be on the next plane home. Our only interest was in the success and efficiency of the BD machines' operation and the quality of yarn produced.⁴⁰

For two years technicians, scientists, and engineers from Courtaulds, VÚB, and Kovostav traveled back and forth across the English Channel. On each visit to Britain, the Czechs found problems that they attributed to inferior maintenance; as late as April 1969, they had made little progress. The parties agreed to work independently on improving the quality of yarn spun from Courtaulds man-made fibers; but by mid-1969, Worrall recalled, the results were still so discouraging “that we stopped delivery on the machines until modifications were made.”

At the end of 1969, the Czech-British collaboration finally achieved a technical breakthrough, and the prospects of the BD 200 suddenly turned bright. Yet how can one explain the tenacity with which both sides pursued this machine? The archives of both the Czechs (the VÚB and Kovostav/Elitex) and the British (Courtaulds) portray meticulous engineers determined to make this machine work, despite all the difficulties in working across the Iron Curtain at that time (language not the least of them). Until 1971, the Czechs and their licensees were the only producers of the technology in which Courtaulds had invested deeply; and on the Czech side, VÚB needed to both test and “showcase” its invention. As Worrall later declared, “the fact that we made a success of it meant that other spinners who bought BDs got better machines.” Dinsdale concurred, “Rohlena recognized our contribution. Now you could buy a machine that could spin man-made fibres.”⁴¹ Indeed, the

⁴⁰ Worrall, interview with author, 20 June 2001, Manchester. One of these technicians, Jiří Faltys, illustrates the opportunities afforded BD 200 workers. Trained as an airplane technician, he joined Kovostav when the Warsaw Pact transferred airplane construction from Czechoslovakia to other CMEA countries. In summer 1968, before the Soviet invasion, he arrived in England with his wife and two small children; three years later he moved on to Charlotte, N.C., and spent another three years working on BD 200s in the United States; he performed the same job in France, from 1977 until 1980; see Faltys, interview with author, 4 July 2001, Ústí. In the 1980s, until 1989, he returned to England, employed by the Czechoslovak trading company Investa to service U.K.-installed machines; see Václav Klička, e-mail to author, 19 Dec. 2006.

⁴¹ One of the few OE specialists in the West in the 1970s, Worrall was always in demand at conferences and textile schools; his “Open-End Rotor Spinning Technology: Part One,” *Textile Month*, May 1978, pp. 29–32, 59, and 70; and “Open-End Rotor Spinning Technology: Part Two,” *Textile Month* (June 1978), 69–71, became part of the textile technology curriculum at Bradford University; Worrall, 16 Dec. 2006, telephone conversation with author. Dinsdale turned his experience into a doctoral dissertation on OE spinning of synthetic fibers (Bradford University, 1971); he received his degree, but Courtaulds pressured the university to keep the

long-term collaboration with a lead user allowed the BD 200 to conquer other markets (see Figure 6, which shows the certificate awarded to VÚB by the British Textile Institute in November 1969; Figure 7 shows a BD 200 in 1970, at a trade show.)



Figure 6 Award from the British Textile Institute, 21 Nov. 1969

One of those markets was the United States, where American textile companies were also struggling with rising labor costs and cheap imports. Many textile people had read the plentiful reports from Britain on developments in OE spinning, and some had undoubtedly spoken with colleagues from Courtaulds. Several of them, including representatives from Carolina Mills, saw the BD 200 for the first time in 1971, at the ITMA trade show in Paris. Because of labor shortages, Carolina Mills had a vacant plant near Charlotte that might experiment with the new technology. The machines were inexpensive at \$35,000 to \$40,000 per machine, and with the promise of at least three times the productivity of ring spinners, they were a bargain.⁴²

dissertation secret for five years; Dinsdale, interview with author, 16 Nov. 2001, Alexandria, Va., and e-mail to author, 13 Dec. 2006.

⁴² Pricing is a difficult issue to research, in part because companies do not like to disclose the results of price negotiations. George Moretz, vice-president of Carolina Mills, cited \$180 per spinning unit (half the cost of ring spindles) when Toyoda was quoting \$220; see his article, "Open-end spinning from the spinner's viewpoint," *Modern Textiles* (June 1974), 24-25. Vice-president for manufacturing Steve Dobbins told me in 1983 that they had cost only \$175 per unit. At any rate, according to Josef Ripka, "people were always commenting on how ridiculously low our prices were";

Soon Carolina Mills had forty-eight spinning machines in one plant, with Czech technicians on hand to assist with installation and maintenance.⁴³

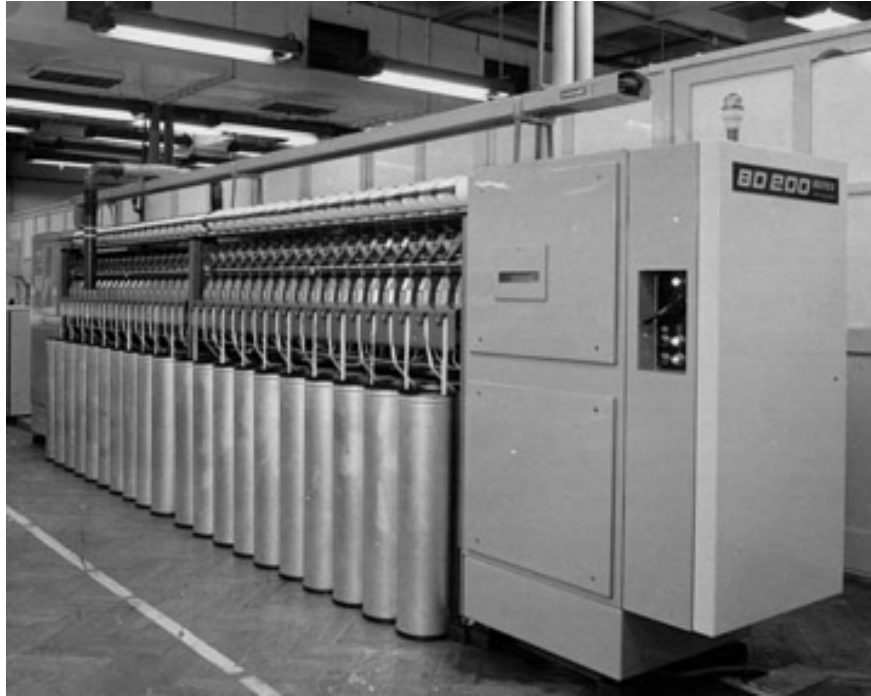

Figure 7 The BD 200

Note sliver is fed from cans, the standard design after about 1970. This is an 80-position model for a trade show. (Source: Rieter CZ, a.s.)

interview with author, 30 Aug. 2000, Ústí. Documents in SOAZ, k. 98 from 10 March 1972 reveal disputes between Toyoda and Polytechna, the Czechoslovak trading agency, in this regard. According to Y. Toyoda, managing director of Toyoda, the Czechs and Japanese had agreed in Nov. 1970 to sell the BD 200s in the United States for no less than \$30,000. Now that their performance was so much better, he proposed that they up the minimum to \$55,000; they compromised on \$42,000 when a machine from Platt was selling for \$70,000-\$80,000. Other sources note that Kovostav and VÚB also disagreed on the worth of their machines in the marketplace, VÚB consistently undervaluing them. In 1974, wrote Moretz, “these machines . . . have increased in price by approximately 100%, Investa’s current quotation being \$350.” At the same time, he reported, Platt, Ingolstadt, and Rieter machines were going for \$500 to \$800 per spindle.” (It would take a few years for spinners to free themselves from the habit of describing spindle-less machines on a “spindle” basis.)

⁴³ Although travel became nearly impossible for most Czechs and Slovaks after Feb. 1970, when the Czechoslovak government sealed the borders, Czech textile machine specialists (including Jiří Faltys and Josef Starý) continued to spend up to three years at a time in Western and developing countries; interviews with author: Faltys and Starý (4 July 2001, Ústí), Vladimír Kapek (15 Feb. 1984, Ústí), Josef Carba (22 Feb. 2005, Choceň).

About the same time, *Textile Industries*, an American trade publication, devoted its July 1972 issue to open-end spinning, featuring interviews with a number of U.S. textile manufacturers.⁴⁴

Two years later George Moretz, vice-president of Carolina Mills, shared in *Modern Textiles* that the savings were multifold: the BD machines needed only four spinners per shift rather than the ten necessary on the ring spinners, and the elimination of roving and winding had saved an additional six jobs per shift. Performance was actually better than expected; the manager of the Carolina Mills' BD plant, Steve Dobbins, noted that the BD 200s could spin "30s" [finer yarn] from the beginning, even though Investa had said they could do only "20s."⁴⁵ In his article, Moretz described several problems encountered with breaking in the machines and explained how they had turned the specific OE yarn characteristics into advantages in several applications. For example, having discovered that the "apparent harshness is due to the higher twist necessary to process yarns on OE machines," they developed new fabrics that could not be made with ring spun yarn. With improvements based on input from early adopters on the fabrication side, Moretz wrote, the yarn manufacturers were able to charge a 15 percent premium for OE yarn over ring spun. A decade later these machines were still running so well that Dobbins, now vice-president for manufacturing, believed that moving from the first generation machines (\$175 per rotor in 1972) to more automation (\$1500 per rotor in 1983) was hard to justify.⁴⁶

From Carolina Mills, the BD 200 spread rapidly in the United States. Hanes Knitwear waited until Vernon Carson, one of their engineers, proved that it could spin yarn suitable for cotton underwear; they installed thirty-six machines in 1980-1981.⁴⁷ These customers were served by Investa's representative in the United States, Omintex, a small office of some 15-20 technicians headed by American textile engineer Cliff Palm. A quintessential pragmatist, Palm did not hesitate to head to the machine shop to make modifications in the Czech machines in order to improve their reliability or performance. The problem, in Palm's view, was that the Czechs refused to

⁴⁴ "OE vs. The Ring," *Textile Industries* (July 1972) (special issue).

⁴⁵ Dobbins, interview with author, 20 April, 1983. This may have been due to Carolina Mills' unusually capable workforce; according to Kovostav installer Vladimir Kapek, who spent several months at Carolina Mills in the 1970s, "it was a joy" to work there. He credited Ed Schrum, not yet president, with this effective work environment (interview with author, 15 Feb. 1984, Ústí). Most Czech technicians described American workers as poorly trained compared to Europeans.

⁴⁶ Dobbins, interview with author, 20 April 1983, at the Carolina Mills plant near Charlotte, N.C.

⁴⁷ The machines were in Hanes' cotton spinning mill in Winston-Salem; Carson recalled that workers (including his mother) were so delighted to see the old machines go that they would have hauled them away for free (interview with author, 21 April 1983, Winston-Salem).

incorporate these necessary modifications at the factory level (“although they do *eventually*”) because of their five-year plan and bonus system.⁴⁸

The success of the BD 200 in Europe and the United States demonstrates that politics did not always eclipse common sense. Leonid Brezhnev’s crushing of the Prague Spring in August 1968 did not immediately affect the BD 200. Even in February 1970, when the Czechoslovak government finally decided to seal the borders, drastically reducing contact between East and West, it continued to protect its star textile machine, whose contribution of hard currency to the state economy was indispensable.⁴⁹ Although competition increased sharply in 1971, as a dozen Western companies entered the OE field, Kovostav (“Elitex Ústí nad Orlicí” after 1976) continued to out-produce and outsell everyone in the OE sector for the next few years, accounting for well over half of all OE machine production worldwide in the mid-1970s.⁵⁰ Even after the BD 200 had reached its peak, VÚB continued to be recognized for having developed a technology that revolutionized the industry. Indeed, in a 1976 article for *Textile Institute and Industry*, British textile scientist Roy Rothwell, anxious about the threat posed by

⁴⁸ Later, in his dissertation, Zdenek Maršíček analyzed at length the dysfunction in the system of remuneration for patents (“Tvorba a realizace”). Cliff Palm explained to the author, exasperated (at ITMA, Milan, Italy, Oct. 1983): “It’s their damn five-year plan and their bonus system. Like this cone take-up over here,” Palm said, pointing to the top of the Elitex machine on display at ITMA 1983. “Some guy invented that, and as long as he has enough political clout, they’ll keep it on the machine, because once it goes off, he loses his bonus. But it will never get off the ground.” Palm proceeded to illustrate how a properly-form cone looks and why the shape is important for knitters. The Americans, just as clever as the Czechs, had developed a device to use with their Czech BDs that would achieve a proper cone, but to Palm’s annoyance, Elitex refused to license it. “They won’t listen to me. Everyone wants a cone take-up, and we don’t have one that works.” For a similar situation in the construction industry, see Sarah Slaughter, “Innovation and Learning during Implementation: A Comparison of User and Manufacturer Innovations,” *Research Policy* 22 (Feb. 1993): 81-95.

⁴⁹ The lucrative business in machines and licenses may have brought in as much as 80 percent of Czechoslovakia’s hard currency in the BD 200’s heyday. According to Maršíček (“Výsledky,” 79–87), by 1982 the Czechs had sold 3,344 machines to the West and 4,392 to the USSR, figures that do not include the spinning (rotor) units sold separately that had become a growing business. Maršíček states the value of the machines sold to the USSR at 2,200 million KSC, but does not give a value to the 3,344 sold to the West. In 1974, BDs sold for around \$350 per rotor, or \$70,000 per machine (Moretz, “Open-end spinning from the spinner’s viewpoint”). Maršíček’s figures (“Výsledky,” 97) show that between 1967 and 1982, the BD 200 captured over 207 million Kčs in license fees and patent-dispute settlements alone.

⁵⁰ See the soft production figures in Ripken, *Innovations-prozesse*, 230. Sales of complete machines to the West peaked in 1975 at 533; thereafter, the BD 200 still led in production, but in an increasing number and proportion of machines went to the Soviet Union; in 1982, only 14 percent of production was sold to the West (Maršíček, “Výsledky,” 83-84).

Czechoslovak and other East European textile machines, urged Western textile machine manufacturers to adopt “radical solutions”: either joint ventures with the East Europeans or tighter cooperation among the West European firms themselves. Certainly, the BD 200 and the Czechs who produced it had made their mark.⁵¹

Conclusion: How Could the BD 200 Emerge from a Communist Country under Cold War Conditions?

Although as a historian I can emphasize only the historical context of the development of the BD 200, both long-term and contemporary, I believe that the highly effective management of the project, the partners, and the politics was the key to the BD 200’s success. I also believe that the eventual decline of the BD 200 had to do with loss of that management expertise, within, to be sure, a changing historical context.

Among the characteristics of the long-term historical context were the traditional industrial strengths in the Czech lands, a high level of education, scientific research, and economic development. The immediate context was the Communist system, the positive aspects of which included, in this case, extreme vertical integration, which promoted very close collaboration among the Cotton Research Institute, the machine manufacturer Kovostav, and the users, the local cotton mills. Moreover, the system allowed unlimited financing if the Communist Party wished it, regardless of objective market criteria (although in this case they were rather strong). Particularly important were the politics of the time, starting with Khrushchev’s reforms of the late 1950s and early 1960s, which spread westward and permitted the Czechoslovak movement that culminated in the Prague Spring, the incubator of many innovations. Yet these economic and political factors were not sufficient to ensure commercial success of even the most promising innovation. The Czechs had many ingenious projects that never made it outside the R&D lab or factory prototype stage.

⁵¹ The outpouring of articles about OE spinning in the mid-1970s testified to the general acceptance of this technology. See *Textile Industries*, July 1972; Worrall, “Open-End Spinning: A Fabricator’s Viewpoint”; Moretz, “Open-end spinning from the spinner’s viewpoint”; Eric Dyson, ed., *Rotor Spinning. Technical and Economic Aspects* (Stockport, 1975), a collection including VÚB authors Ripka and Kašpárek; F. Bancroft; and C. A. Lawrence, *Progress in O-E Spinning. World Literature Survey, 1968–1974* (Manchester, 1975). See also Lord, “Commercial Development in Open-end Spinning,” Catling, “The Economics of Open-End Spinning,” and H. V. Shaw, “Open-End Spun Yarns: Their Processing Performance and Fabric Characteristics,” in *The Yarn Revolution*, 1–14, 38–47, and 62–75. Lord anticipated a slump in OE machine sales, Catling was more optimistic. Roy Rothwell’s warnings appear in “Innovation in Textile Machinery: The Czechoslovak Experience,” *Textile Institute and Industry* (Dec. 1977), 421–22. Stories about Czechoslovak textile machine innovations continued to appear in the trade press through the mid-1980s.

Based on interviews and archival research, my study reveals that effective project management and strategic Western partners were the unexpected and decisive elements in the international success of this machine. Project management was most important in the early years, from around 1960 to the mid-1970s. Here Vaclav Rohlena, a hard-line believing Communist, married the best of collectivist ideology—teamwork, team principles—with common-sense project management: if we are going to have teams, why not several, and why should they not work on different approaches simultaneously? In addition, why not test these approaches as they emerge, rather than following a linear path of development? Moreover, if we are going to have teams, let us mix it up: let us make them interdisciplinary and be sure we have experienced engineers, scientists, and technicians paired with newly minted university graduates “so inexperienced that they didn’t know that anything was impossible.” Finally, the managers kept the team members focused on their tasks and the project’s objective, while understanding the importance of allowing creativity to flourish independently of management rules and structures. To be sure, this project recruited some of the best engineers and scientists in the country, and serendipity played a role more than once, but without effective management, the BD 200 could not have achieved world fame. Although somewhere in the West, perhaps among some pragmatic Americans, such principles may have been in operation, by the time U.S. business schools began to study them, they were attributed to the Japanese.

Yet this effective project management was not the only kind of management that proved essential to the BD 200’s success. The seeking out, negotiating, and implementing of partnerships was critical as well. Certainly the astutely formed partnership with the Soviet Union allowed “almost unlimited” funds for the project and assured a vast market for the machines. Without Western partners, however, the Czechs probably could not have brought their machine to market-based commercial success. The manufacturing license agreement with Japan opened up the market, bringing credibility and stimulating demand and further innovation.⁵² Perhaps most important was the lead user, Courtaulds, which assured that the BD 200 could be used in a world that craved synthetic yarns. Overall, the parties involved ignored ideology: market forces may have been the ultimate evil according to Karl Marx, but those very forces ensured the success of this “communist” machine. When it served the state’s interest, the Communist Party’s top organs ignored the otherwise rigid boundary of the Iron Curtain and permitted talent, ideas, and material goods to permeate it.

Epilogue

The larger political and economic forces of both the Soviet Union and Western capitalist democracies inevitably affected the fate of the first open-

⁵² Details on this and other agreements, on patents, production, exports, and revenues are in Maršíček, “Výsledky,” 87-98.

end spinning machine, the BD 200 from Communist Czechoslovakia. The ČSSR emulated the increased control from Moscow that characterized the Brezhnev era (1964–1982), negatively affecting the BD 200. As foreign trade was further centralized, leaving VÚB and Kovostav/Elitex with little direct customer contact, the creative interaction with BD 200 users formerly enjoyed by Ústí engineers and technicians disappeared. Moreover, these changes squeezed out managers unwilling to be subservient to central control. This, along with complacency born of success, gradually resulted in a narrow approach to further development that focused only on productivity (speed), not on the yarn quality demanded by users.⁵³ Moreover, as electronic controls and other devices became the *sine qua non* for OE machines in the West, the Czechs could not keep up. They not only suffered from the Western embargo on strategic electronic components, but the system did not allow them to develop their own.⁵⁴ By the early 1980s, they had lost their leading position in the West, where they would soon command only 5 percent of the market—even while hundreds of machines were still flowing to the USSR and developing countries. Thus a dogmatically recentralized economy, which resulted in weakened ties to customers and constrained management, suppressed entirely the advantages of the centrally planned economy that had contributed to their earlier success. The deathblow came in November 1989, with the fall of the Communist government. It would be more than a decade before textile machines again became a stable, if much smaller, part of Czech industry.⁵⁵

After 1989, Czech manufacturers of textile equipment were abandoned to their own inadequate devices. Their once huge industry (25,000 employees) collapsed, suffering from the worldwide slump in textiles, the loss of the Soviet market, and the lack of strategic industrial policy at the state level. VÚB immediately downsized to some 90 employees; in 2006, it was

⁵³ This is lamented in several documents; see, for example, the anonymous “Vznik BD předení, postavení čs. strojů ve světě a podmínky tehdejší rychlé realizace [The origins of open-end spinning, the position of the Czechoslovak machines in the world, and the conditions for rapid implementation (of the project) in the past]”; SOAZ VÚB, k. 39, an extensive analysis from VÚB (late 1976 or early 1977, internal evidence); a long letter from Miroslav Hájek, head of the cotton industry, to minister Bohumil Urban, (MZO ČSSR, 21 Dec. 1981, Hradec Králové, c. j. 1/926/81, SOAZ VÚB, k. 655 II–3/802; and Marsicek, “Tvorba a realizace inovační strategie.”

⁵⁴ Stokes, *Constructing Socialism*, chap. 8, illuminates East Germany’s flawed attempt to catch up with the West in microelectronics, arguing that poor strategy, not lack of talent, doomed the effort.

⁵⁵ Rohlena retired in 1978, remaining active in the KSC and becoming director of the Center for the History of the Textile and Clothing Industry in the ČSSR (Středisko pro dějiny textilního a oděvního průmyslu v ČSSR), established at VÚB in 1980. VÚB’s West German, Swiss, and Italian competitors continued to renew their licensing agreements until at least 1987; see Kašpárek et al., *40 let VÚB*, 162–63.

manufacturing specialty yarns, conducting commissioned textile research, and providing textile engineering consulting services.⁵⁶

In 1994, Rieter, a former competitor and licensee, purchased Kovostav/Elitex in a deal brokered by the International Finance Corporation. The Swiss company originally intended to use the depressed plant for spare parts, but recognizing the strengths of the Czech engineering and technical staff, it opted to upgrade the facility and increase the number of workers. Rieter CZ, a.s. (joint-stock company), under Czech management since privatization with Václav Klička serving as chief executive officer, was named “the most admired company” in the Czech Republic in 2004; in 2006, it employed 1,100 workers, producing OE machines and other products.⁵⁷

⁵⁶ See their website; viewed Oct. 9, 2007. URL: www.vubas.cz.

⁵⁷ See their website; viewed Oct. 9, 2007. URL: www.rieter.cz.